

# HILTI

## DG 150

<b>Bedienungsanleitung</b>	<b>de</b>
<b>Operating instructions</b>	<b>en</b>
<b>Mode d'emploi</b>	<b>fr</b>
<b>Istruzioni d'uso</b>	<b>it</b>
<b>Gebbruksaanwijzing</b>	<b>nl</b>
<b>Manual de instruções</b>	<b>pt</b>
<b>Manual de instrucciones</b>	<b>es</b>
<b>Οδηγίες χρήσεως</b>	<b>el</b>
<b>Kullanma Talimatı</b>	<b>tr</b>
<b>دليل الاستعمال</b>	<b>ar</b>

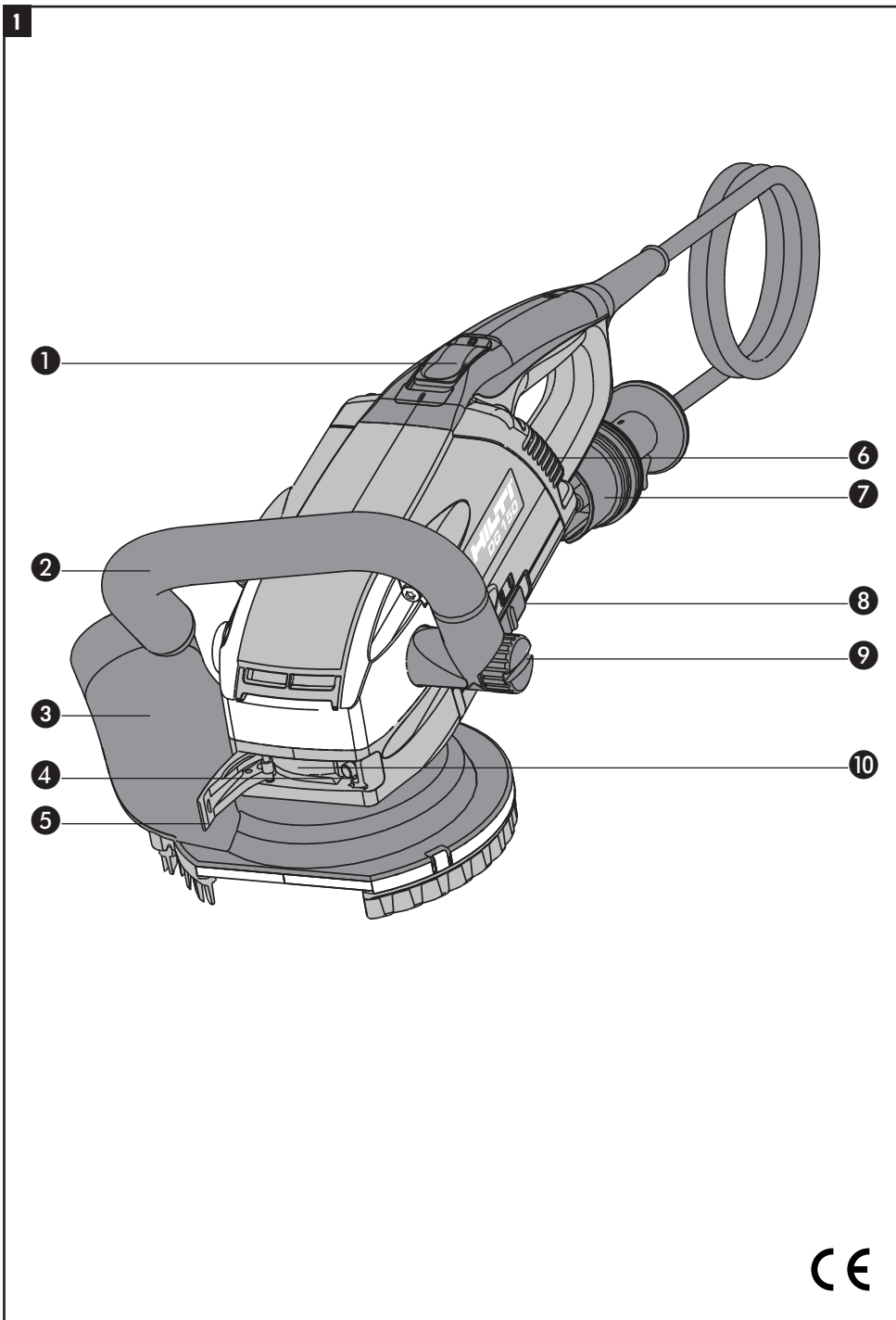



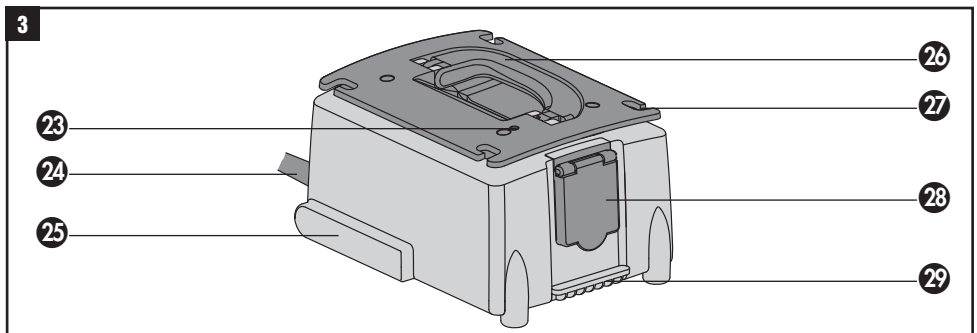
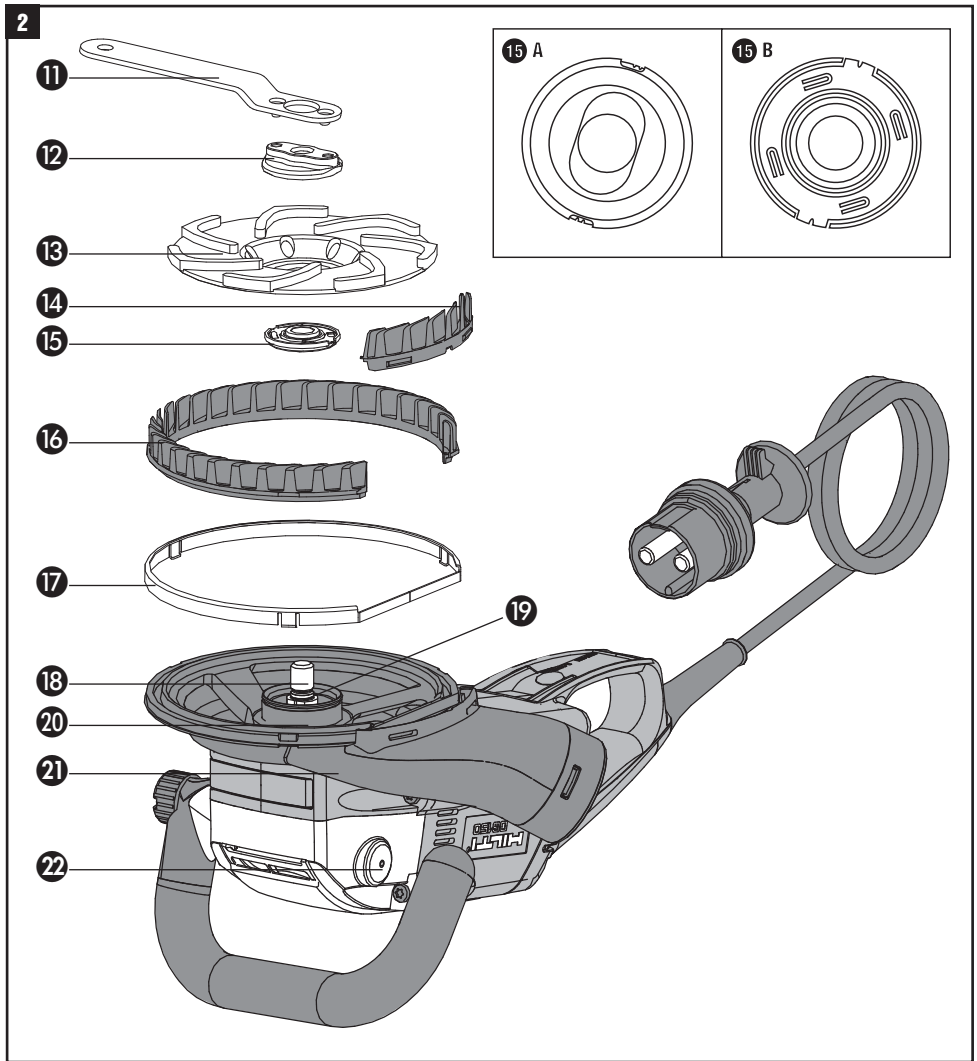

# ORIGINAL OPERATING INSTRUCTIONS

## DG 150 grinder with DPC 20

**It is essential that the operating instructions are read before the tool is operated for the first time.**

**Always keep these operating instructions together with the tool.**

**Ensure that the operating instructions are with the tool when it is given to other persons.**

Contents	Page
1. General information	13
2. Description	14
3. Tools and accessories	15
4. Technical data	15
5. Safety precautions	16
6. Before use	20
7. Operation	21
8. Care and maintenance	22
9. Troubleshooting	22
10. Disposal	22
11. Manufacturer's warranty – tools	23
12. Declaration of conformity (original)	23

### Operating controls and component parts of the DG 150 **1** **2**

- 1 On / off switch
- 2 Side handle
- 3 Guard assembly
- 4 Adjusting screw
- 5 Clamping lever
- 6 Indicator lamp (LED)
- 7 Supply cord plug
- 8 Speed control switch (settings 1 and 2)
- 9 Side handle fastening screw
- 10 Clamping band
- 11 Wrench
- 12 Clamping nut
- 13 Diamond cup wheel
- 14 Lamellar seal, small
- 15 Clamping flange
- 16 Lamellar seal, large
- 17 Retaining ring
- 18 Spindle
- 19 Circlip
- 20 Guard lower section
- 21 Guard upper section with hose connector
- 22 Spindle lockbutton

### Operating controls and component parts of the DPC 20 **3**

- 23 Indicator lamp (LED)
- 24 Supply cord
- 25 Guide rib
- 26 Carrying handle
- 27 Supply cord holder
- 28 Electric socket with cover
- 29 Locking lug

## 1. General information

**1** These numbers refer to the tool's operating controls or indicators.

**1** These numbers refer to the corresponding illustrations. The illustrations can be found on the fold-out cover pages. Keep these pages open while studying the operating instructions.

In these operating instructions, the DG 150 with the DPC20 is referred to as «the tool».

### Location of identification data on the tool

The type designation and serial number can be found on the type plate on the tool. Make a note of this data in your operating instructions and always refer to it when making an enquiry to your Hilti representative or service department.

Type: \_\_\_\_\_

Serial no.: \_\_\_\_\_

Type: \_\_\_\_\_

Serial no.: \_\_\_\_\_

## 1.1 Indication of danger

### -WARNING-

Used to draw attention to a potentially dangerous situation which could lead to serious personal injury or fatal accident.

### -CAUTION-

Used to draw attention to a potentially dangerous situation which could lead to minor personal injury or damage to the equipment or other property.

### -NOTE-

Used to draw attention to an instruction or other useful information. It is not used to indicate dangerous situations or situations that could lead to damage to the equipment or other property.

## 1.2 Pictograms

### Warning signs



General warning



Warning: electricity



Warning: avoid hand injuries



Warning: hot surface

### Obligation signs



Wear eye protection



Safety helmet must be worn



Wear ear protection



Wear protective gloves



Wear breathing protection



Wear protective clothing



Read the operating instructions before use.



Return waste material for recycling

**RPM** /min

revolutions per minute      revolutions per minute

## 2. Description

The DG 150 is an electrically-powered diamond grinding tool for use by tradesmen in the construction industry for grinding mineral materials. The DG 150 can be operated only in conjunction with the DPC 20 which, together, thus form a system.

### Use of the product as directed

The DG 150 may be operated only in conjunction with the DPC 20. Together with the industrial vacuum cleaner recommended by Hilti and the appropriate DG-CW 150/6" diamond cup wheels, the DG 150 forms an electrically-powered, hand-guided grinding system that keeps dust to a minimum. In order to ensure optimum dust extraction, an industrial vacuum cleaner in good working condition must be used at all times. To ensure safe operation, the DG 150 may be used only together with original Hilti cup wheels. The DG 150 is designed exclusively for dry grinding on the surface of concrete or similar mineral materials and for removing thin coatings, with a maximum thickness of 3 mm, from these materials. The locally applicable health regulations and corresponding safety precautions must be observed and implemented at all times while grinding coated or uncoated mineral materials with the DG 150.

**Do not, under any circumstances, use the tool in any way other than as described in the operating instructions.**

- The tool is not suitable for grinding metals, wood or other materials not listed at paragraph 2.
- The tool is not suitable for use with diamond cutting discs, abrasive cutting or grinding discs, wire brushes or other insert tools not approved for use (see section 3).
- The tool is not suitable for wet grinding.
- Do not clamp the tool in a vice.
- Grinding materials containing asbestos is not permissible.
- Materials containing substances hazardous to health may be ground only after consultation with the local authority responsible for safety at work and in accordance with the locally applicable regulations concerning safety at work.
- Diamond cup wheels, clamping flanges and clamping nuts not listed in section 3 "Diamond cup wheels and accessories" may not be used

- Grinding off projecting objects such as nails and screws etc. is not permissible. Such objects must be removed carefully before beginning grinding.

#### Items supplied

1	DG 150 grinder
1	DPC 20 power conditioner
1	Clamping flange
1	Clamping nut
1	Wrench
1	Protective goggles
1	Operating instructions

### 3. Diamond cup wheels and accessories

#### Hilti item

Diamond cup wheels	Use/material
DG-CW 150/6" A1	Grinding highly abrasive materials such as screed and similar mineral materials
DG-CW 150/6" B1	Grinding to remove coatings with a maximum layer thickness of 3 mm from concrete and similar mineral materials
DG-CW 150/6" C1	Grinding concrete and similar mineral materials of medium hardness and medium abrasiveness
DG-CW 150/6" C10	Grinding concrete
DG-CW 150/6" C2	Grinding concrete and similar very hard and highly abrasive mineral materials
DG-CW 150/6" D1	Fine finishing of concrete and similar mineral material surfaces
Lamellar seals	One large lamellar seal and one small lamellar seal
Retaining ring	Retaining ring for attaching the large lamellar seal to the dust hood
DG 150 toolbox	Carrying case
VCD 50L	Dry-type vacuum cleaner
Clamping flange for DG 150	Special quick-stop compatible clamping flange to be used exclusively for fitting Hilti DG-CW 150/6" diamond cup wheels
Clamping nut for DG 150	Special M13 clamping nut for fitting Hilti DG-CW 150/6" diamond cup wheels

### 4. Technical data

	DG 150	DPC 20					
Nominal voltage		100 V	110 V	120 V	220 V	230 V	240 V
Nominal current		15 A	16 A	15 A	9.6 A	9.2 A	8.8 A
Power input		1500 W	1760 W	1800 W	2100 W	2100 W	2100 W
Power output		1070 W	1260 W	1285 W	1500 W	1500 W	1500 W
Mains frequency		50/60 Hz	50/60 Hz	60 Hz	50/60 Hz	50 Hz	50 Hz
Rated speed at setting no.1	4700 /min						
Rated speed at setting no.2	6600 /min						
Weight in accordance with EPTA procedure 01/2003	4.1 kg	3.8 kg	3.8 kg	3.8 kg	3.4 kg	3.4 kg	3.4 kg

Dimensions (l×w×h)	46×25×23 cm	27×22×15 cm
Electrical protection class	Protection class II  (double insulated)	

**-NOTE-**

The vibration emission level given in this information sheet has been measured in accordance with a standardised test given in EN 60745 and may be used to compare one tool with another. It may be used for a preliminary assessment of exposure. The declared vibration emission level represents the main applications of the tool. However if the tool is used for different applications, with different accessories or poorly maintained, the vibration emission may differ. This may significantly increase the exposure level over the total working period. An estimation of the level of exposure to vibration should also take into account the times when the tool is switched off or when it is running but not actually doing the job. This may significantly reduce the exposure level over the total working period. Identify additional safety measures to protect the operator from the effects of vibration such as: maintain the tool and the accessories, keep the hands warm, organisation of work patterns.

**Noise and vibration information (measured in accordance with EN 60745):**

Typical A-weighted sound pressure level	88 dB (A)
Typical A-weighted sound power level	99 dB (A)
Uncertainty	3 dB
Triaxial vibration values	5,8 m/s <sup>2</sup>
Uncertainty (K)	1,5 m/s <sup>2</sup>

**Other significant characteristics of the appliance**

Time to stop after switching off ≤ 2 sec.

Thermal overload protection

Restart safety interlock

Right of technical changes reserved

**5. Safety instructions****5.1 General power tool safety warnings**

**WARNING! Read all safety warnings and all instructions.** Failure to follow the warnings and instructions may result in electric shock, fire and/or serious injury. **Save all warnings and instructions for future reference.** The term "power tool" in the warnings refers to your mains-operated (corded) power tool or battery-operated (cordless) power tool.

**5.1.1 Work area safety**

- Keep work area clean and well lit.** Cluttered or dark areas invite accidents.
- Do not operate power tools in explosive atmospheres, such as in the presence of flammable liquids, gases or dust.** Power tools create sparks which may ignite the dust or fumes.
- Keep children and bystanders away while operating a power tool.** Distractions can cause you to lose control.

**5.1.2 Electrical safety**

- Power tool plugs must match the outlet. Never modify the plug in any way. Do not use any adapter plugs with earthed (grounded) power tools.** Unmodified plugs and matching outlets will reduce risk of electric shock.
- Avoid body contact with earthed or grounded surfaces, such as pipes, radiators, ranges and refrigerators.** There is an increased risk of electric shock if your body is earthed or grounded.
- Do not expose power tools to rain or wet conditions.** Water entering a power tool will increase the risk of electric shock.
- Do not abuse the cord. Never use the cord for carrying, pulling or unplugging the power tool. Keep cord away from heat, oil, sharp edges or moving parts.** Damaged or entangled cords increase the risk of electric shock.
- When operating a power tool outdoors, use an extension cord suitable for outdoor use.** Use of a cord suitable for outdoor use reduces the risk of electric shock
- If operating a power tool in a damp location is unavoidable, use a residual current device (RCD) protected supply.** Use of an RCD reduces the risk of electric shock.

### 5.1.3 Personal safety

- a) **Stay alert, watch what you are doing and use common sense when operating a power tool. Do not use a power tool while you are tired or under the influence of drugs, alcohol or medication.** A moment of inattention while operating power tools may result in serious personal injury.
- b) **Use personal protective equipment. Always wear eye protection.** Protective equipment such as dust mask, non-skid safety shoes, hard hat, or hearing protection used for appropriate conditions will reduce personal injuries.
- c) **Prevent unintentional starting. Ensure the switch is in the off-position before connecting to power source and/or battery pack, picking up or carrying the tool.** Carrying power tools with your finger on the switch or energising power tools that have the switch on invites accidents.
- d) **Remove any adjusting key or wrench before turning the power tool on.** A wrench or a key left attached to a rotating part of the power tool may result in personal injury.
- e) **Do not overreach. Keep proper footing and balance at all times.** This enables better control of the power tool in unexpected situations.
- f) **Dress properly. Do not wear loose clothing or jewellery. Keep your hair, clothing and gloves away from moving parts.** Loose clothes, jewellery or long hair can be caught in moving parts.
- g) **If devices are provided for the connection of dust extraction and collection facilities, ensure these are connected and properly used.** Use of dust collection can reduce dust-related hazards.

### 5.1.4 Power tool use and care

- a) **Do not force the power tool. Use the correct power tool for your application.** The correct power tool will do the job better and safer at the rate for which it was designed.
- b) **Do not use the power tool if the switch does not turn it on and off.** Any power tool that cannot be controlled with the switch is dangerous and must be repaired.
- c) **Disconnect the plug from the power source and/or the battery pack from the power tool before making any adjustments, changing accessories, or storing power tools.** Such preventive safety measures reduce the risk of starting the power tool accidentally.
- d) **Store idle power tools out of the reach of children and do not allow persons unfamiliar with the power tool or these instructions to operate the power tool.** Power tools are dangerous in the hands of untrained users.
- e) **Maintain power tools. Check for misalignment or binding of moving parts, breakage of parts and any other condition that may affect the power tool's operation. If damaged, have the power tool repaired before use.** Many accidents are caused by poorly maintained power tools.

- f) **Keep cutting tools sharp and clean.** Properly maintained cutting tools with sharp cutting edges are less likely to bind and are easier to control.
- g) **Use the power tool, accessories and tool bits etc. in accordance with these instructions, taking into account the working conditions and the work to be performed.** Use of the power tool for operations different from those intended could result in a hazardous situation.

### 5.1.5 Service

- a) **Have your power tool serviced by a qualified repair person using only identical replacement parts.** This will ensure that the safety of the power tool is maintained.

### 5.2 Special safety instructions

- a) **This power tool is intended to function as a grinder. Read all safety warnings, instructions, illustrations and specifications provided with this power tool.** Failure to follow all instructions listed below may result in electric shock, fire and/or serious injury.
- b) **Operations such as sanding, wire brushing, polishing or cutting-off are not recommended to be performed with this power tool.** Operations for which the power tool was not designed may create a hazard and cause personal injury.
- c) **Do not use accessories which are not specifically designed and recommended by the tool manufacturer.** Just because the accessory can be attached to your power tool, it does not assure safe operation.
- d) **The rated speed of the accessory must be at least equal to the maximum speed marked on the power tool.** Accessories running faster than their rated speed can break and fly apart.
- e) **The outside diameter and the thickness of your accessory must be within the capacity rating of your power tool.** Incorrectly sized accessories cannot be adequately guarded or controlled.
- f) **The arbour size of wheels, flanges, backing pads or any other accessory must properly fit the spindle of the power tool.** Accessories with arbour holes that do not match the mounting hardware of the power tool will run out of balance, vibrate excessively and may cause loss of control.
- g) **Do not use a damaged accessory. Before each use inspect the accessory such as abrasive wheels for chips and cracks, backing pad for cracks, tear or excess wear, wire brush for loose or cracked wires. If power tool or accessory is dropped, inspect for damage or install an undamaged accessory. After inspecting and installing an accessory, position yourself and bystanders away from the plane of the rotating accessory and run the power tool at maximum no-load speed for one minute.** Damaged accessories will normally break apart during this test time.
- h) **Wear personal protective equipment. Depending on application, use face shield, safety goggles or safety glasses. As appropriate, wear dust mask, hearing protectors, gloves and workshop apron capable**



**of stopping small abrasive or workpiece fragments.**

The eye protection must be capable of stopping flying debris generated by various operations. The dust mask or respirator must be capable of filtering particles generated by your operation. Prolonged exposure to high intensity noise may cause hearing loss.

- i) **Keep bystanders a safe distance away from work area. Anyone entering the work area must wear personal protective equipment.** Fragments of workpiece or of a broken accessory may fly away and cause injury beyond immediate area of operation.
- j) **Hold power tool by insulated gripping surfaces only, when performing an operation where the cutting accessory may contact hidden wiring or its own cord.** Cutting accessory contacting a "live" wire may make exposed metal parts of the power tool "live" and shock the operator.
- k) **Position the cord clear of the spinning accessory.** If you lose control, the cord may be cut or snagged and your hand or arm may be pulled into the spinning accessory.
- l) **Never lay the power tool down until the accessory has come to a complete stop.** The spinning accessory may grab the surface and pull the power tool out of your control.
- m) **Do not run the power tool while carrying it at your side.** Accidental contact with the spinning accessory could snag your clothing, pulling the accessory into your body.
- n) **Regularly clean the power tool's air vents.** The motor's fan will draw the dust inside the housing and excessive accumulation of powdered metal may cause electrical hazards.
- o) **Do not operate the power tool near flammable materials.** Sparks could ignite these materials.
- p) **Do not use accessories that require liquid coolants.** Using water or other liquid coolants may result in electrocution or shock.

**5.2.1 Further safety instructions for all operations****Kickback and related warnings**

Kickback is a sudden reaction to a pinched or snagged rotating wheel, backing pad, brush or any other accessory. Pinching or snagging causes rapid stalling of the rotating accessory which in turn causes the uncontrolled power tool to be forced in the direction opposite of the accessory's rotation at the point of the binding.

For example, if an abrasive wheel is snagged or pinched by the workpiece, the edge of the wheel that is entering into the pinch point can dig into the surface of the material causing the wheel to climb out or kick out. The wheel may either jump toward or away from the operator, depending on direction of the wheel's movement at the point of pinching. Abrasive wheels may also break under these conditions.

Kickback is the result of power tool misuse and/or incorrect operating procedures or conditions and can be avoided by taking proper precautions as given below.

- a) **Maintain a firm grip on the power tool and position your body and arm to allow you to resist kickback forces. Always use auxiliary handle, if provided, for maximum control over kickback or torque reaction during start-up.** The operator can control torque reactions or kickback forces, if proper precautions are taken.
- b) **Never place your hand near the rotating accessory.** Accessory may kickback over your hand.
- c) **Do not position your body in the area where power tool will move if kickback occurs.** Kickback will propel the tool in direction opposite to the wheel's movement at the point of snagging.
- d) **Use special care when working corners, sharp edges etc. Avoid bouncing and snagging the accessory.** Corners, sharp edges or bouncing have a tendency to snag the rotating accessory and cause loss of control or kickback.
- e) **Do not attach a saw chain woodcarving blade or toothed saw blade.** Such blades create frequent kickback and loss of control.

**5.2.2 Safety warnings specific for grinding operations**

- a) **Use only wheel types that are recommended for your power tool and the specific guard designed for the selected wheel.** Wheels for which the power tool was not designed cannot be adequately guarded and are unsafe.
- b) **The guard must be securely attached to the power tool and positioned for maximum safety, so the least amount of wheel is exposed towards the operator.** The guard helps to protect operator from broken wheel fragments and accidental contact with wheel.
- c) **Wheels must be used only for recommended applications. For example: do not grind with the side of cut-off wheel.** Abrasive cut-off wheels are intended for peripheral grinding, side forces applied to these wheels may cause them to shatter.
- d) **Always use undamaged wheel flanges that are of correct size and shape for your selected wheel.** Proper wheel flanges support the wheel thus reducing the possibility of wheel breakage. Flanges for cut-off wheels may be different from grinding wheel flanges.
- e) **Do not use worn down wheels from larger power tools.** Wheel intended for larger power tool is not suitable for the higher speed of a smaller tool and may burst.

**5.3 Additional safety instructions****5.3.1 Personal safety**

- a) Take care to avoid tripping over the supply cord, extension cord or extraction hose.
- b) The side handle must be fitted to the tool at all times when in use.
- c) Keep the grips dry, clean and free from oil and grease.
- d) The tool must be held by both hands when in use.

- e) **Improve the blood circulation in your fingers by relaxing your hands and exercising your fingers during breaks between working.**
- f) **Check each time before using the power tool, including after work breaks, that the wheel is fitted securely.**

**-CAUTION-**

The rotating wheel presents a risk of injury. **Accidentally, operate the power tool only when the wheel is directed toward the workpiece.**

- g) Use clamps or a vice to secure loose workpieces.
- h) Take care to avoid concealed electric cables, gas and water pipes. Check the working area, e.g. using a metal detector.
- i) Sparks may fly when grinding. Take care to ensure that flying sparks do not present a hazard to other persons.
- j) Conductive dust may collect inside the tool when grinding conductive materials. This may have a negative effect on the insulation of the tool and cause electric shocks. As a result, tools used for this application must be checked by a technical specialist or Hilti service department at least every six months to ensure integrity of the insulation and to check for possible accumulation of conductive dust or other conductive substances.
- k) **-CAUTION-** The tool continues to run for approx. 2 seconds after switching off.
- l) **The tool is not intended for use by children, by debilitated persons or those who have received no instruction or training.**
- m) **Children must be instructed not to play with the tool.**



- n) Observe the direction-of-rotation arrow when fitting a wheel.



- o) Do not touch the supply cord in the event of it becoming damaged while working. Disconnect the supply cord plug from the socket.
- p) Test new wheels by running them at maximum no-load speed for at least 30 seconds.
- q) **-WARNING-** Do not disconnect the plug of the DG 150 from the power unit DPC 20 under load.
- r) **Hold tool by insulated gripping surfaces when performing an operation where the cutting tool may contact hidden wiring or its own cord.** Contact with a "live" wire will make exposed metal parts of the tool "live" and shock the operator.



- s) The diamond cup wheel, parts of the guard or the tool (gearing section) may become hot during operation.

To avoid burns, do not touch these parts with the bare hands. Wear safety gloves.



- t) Connect the tool to the industrial vacuum cleaner.
- u) Unless stated otherwise in the operating instructions, damaged protective equipment and parts must be correctly repaired or replaced at an accredited service workshop.
- v) For safety reasons, the tool may be operated only when the guard and when safety gloves are worn.
- w) The guard may be adjusted only when the tool has been switched off and the supply cord unplugged.

Grinding may produce hazardous dust.

- x) Before starting work, find out to which dangerous material class the grinding dust produced belongs. Use the tool in conjunction with an industrial vacuum cleaner with an officially approved safety classification and which complies with the local dust protection regulations.
- y) When grinding, the industrial vacuum cleaner used must be equipped with a filter suitable for the application.
- z) Dust from material such as paint containing lead, some wood species, minerals and metal may be harmful. Contact with or inhalation of the dust may cause allergic reactions and/or respiratory diseases to the operator or bystanders. Certain kinds of dust are classified as carcinogenic such as oak and beech dust especially in conjunction with additives for wood conditioning (chromate, wood preservative). Material containing asbestos must only be treated by specialists. **Where the use of a dust extraction device is possible it shall be used. To achieve a high level of dust collection, use a suitable vacuum cleaner of the type recommended by Hilti for wood dust and/or mineral dust together with this tool. Ensure that the workplace is well ventilated. The use of a dust mask of filter class P2 is recommended. Follow national requirements for the materials you want to work with.**



**5.3.2 Personal protective equipment**

- a) Always wear eye protection, a safety helmet, ear protection, safety gloves, breathing protection and protective clothing when grinding.
- b) Wear knee protectors when working on floors.



## 6. Before use

It is essential that the safety precautions printed in these operating instructions are read and observed.

  	<p><b>-CAUTION-</b></p> <ul style="list-style-type: none"> <li>■ The cup wheel or parts of the guard may become hot during use.</li> <li>■ These parts may burn your hands.</li> <li>■ Wear safety gloves when changing the cup wheel or adjusting the guard.</li> </ul>
---	--

### 6.1 Guard

**-WARNING-** The tool may be used only with the guard fitted.

A damaged or incomplete guard must be replaced immediately.

#### 6.1.1 Adjusting the guard

The extraction hose connector can be brought into the most favourable position for working by rotating the entire guard.

##### Rotating the guard

1. Switch the tool off.
2. Disconnect the supply cord plug from the socket.
3. Open the clamping lever.
4. Rotate the guard.

**-NOTE-** When the extraction hose connector comes into contact with the opened lever, the guard can be rotated further by moving it downwards.

5. Close the clamping lever.

#### 6.1.2 Adjusting the guard to the work surface

1. Switch the tool off.
2. Disconnect the supply cord plug from the socket.
3. Lay the tool down on the cup wheel.
4. Open the clamping lever.
5. Rotate the guard and adjust it to the optimum height.

**-NOTE-** For optimum dust extraction while grinding, the lamellar seal should be almost in contact with the work surface (gap 0 ... 1 mm).

6. Close the clamping lever.

#### 6.1.3 Adjusting the guard for working close to edges

The opening in the lower section of the guard can be rotated until part of the cup wheel is exposed. This is of advantage, for example, when grinding close to a wall.

	<p><b>-WARNING-</b></p> <ul style="list-style-type: none"> <li>■ The guard is used in a partly open position for working close to edges.</li> <li>■ The rotating cup wheel presents a risk of serious injury.</li> <li>■ Work carefully when the guard is open and close it again when you have finished working at the edge.</li> </ul>
---	--

**-NOTE-** More dust may escape from the guard when working at edges.

### Adjusting the guard

1. Switch the tool off.
2. Disconnect the supply cord plug from the socket.
3. Open the clamping lever.
4. Rotate the upper and lower sections of the guard in opposing directions until they are in a suitable position.
5. Close the clamping lever

**-NOTE-** The guard engages perceptibly in the closed, normal position.

**-NOTE-** If the guard is not held securely when the lever is closed, tighten the clamping band by turning the adjusting screw in a clockwise direction.

If the guard cannot be moved when the lever is open, release the clamping band by turning the adjusting screw in a counter-clockwise direction.

### 6.2 Side handle

#### 6.2.1 Using and adjusting the side handle

For safety reasons, the side handle must always be used. It can be adjusted in two axes until in the most favourable working position:

- Two angled positions for right or left-handed use
- Pivoted forwards / back in increments

1. Switch the tool off.
2. Disconnect the supply cord plug from the socket.
3. Release the side handle by turning the clamping screw in a counter-clockwise direction.
4. Bring the side handle into the desired position.
5. Tighten the clamping screw by turning it in a clockwise direction.

#### 6.3 Diamond cup wheel

● The tool must always be switched off and the supply cord plug disconnected before manipulating the cup wheel in any way.

● Press in the spindle lockbutton (only when rotation has stopped).

● When changing the cup wheel, clean all cup wheel mounting parts.

● Use only original Hilti diamond cup wheels, clamping flanges and clamping nuts.

### 6.3.1 Fitting the diamond cup wheel

1. Place the clamping flange on the spindle, with the O-shaped recess underneath, ensuring that it engages securely. **15A**
2. Place the cup wheel on the centering collar of the clamping flange. **15B**
3. Screw on the clamping nut in a clockwise direction and tighten it by hand or with the wrench against the resistance of the motor / gearing.

### 6.3.2 Removing the diamond cup wheel

1. Press in the spindle lockbutton and hold it in this position.
2. Release the clamping nut by turning it with the wrench in a counter-clockwise direction.
3. Release the spindle lockbutton.
4. Remove the diamond cup wheel.

### 6.3.3 Changing the speed setting

The tool provides two different speed settings.

#### Recommendation

Setting I: 4700 /min

Use this setting for grinding soft mineral materials such as paint coatings on cement rendering. At this speed setting, dust extraction performance is improved and the tool can be guided more easily for removing coatings from soft materials.

Setting II: 6600 /min

Use this setting for grinding hard mineral materials such as concrete, screed or rock in order to obtain full grinding performance.

## 7. Operation

It is essential that the safety precautions printed in these operating instructions are read and observed.

	<b>-CAUTION-</b>
	<ul style="list-style-type: none"> <li>■ Grinding may produce hazardous dust.</li> </ul>
	<ul style="list-style-type: none"> <li>■ The dust produced by grinding may be damaging to the lungs and eyes.</li> </ul>
	<ul style="list-style-type: none"> <li>■ Use a dust extraction system, wear a safety helmet, breathing protection and eye protection.</li> </ul>

	<b>-CAUTION-</b>
	<ul style="list-style-type: none"> <li>■ The tool and the grinding operation emit noise.</li> <li>■ Excessive noise may damage the hearing.</li> <li>■ Wear ear protection.</li> </ul>

### 7.1 Switching the tool on

1. Connect the hose between the tool and the industrial vacuum cleaner.
2. Connect the electric cable between the DG 150 and the DPC 20.
3. Connect the DPC 20 to the mains supply.
4. Lift the tool away from the work surface.
5. Push the on / off switch forward to the ON (I) position. The switch engages in the ON (I) position. After a power cut, the tool can be restarted by moving the on / off switch to the OFF (0) position and then to the ON (I) position.

### 7.2 Testing new diamond cup wheels

Allow the tool to run for at least 30 seconds under no load. The diamond cup wheel should not be used if it vibrates. Do not subject diamond cup wheels to impacts and keep them free from grease.

### 7.3 Grinding

- Caution. During testing, operation and until the cup wheel has come to a stop, the DG 150 should always be operated in contact with or close to the material.
- Never operate the tool without its protective equipment.
- Use only Hilti DG-CW 150/6" diamond cup wheels.
- Apply moderate pressure, appropriate to the material being ground. Move the tool from side to side and do not press the diamond cup wheel into the material.
- The diamond cup wheel may overheat and suffer damage when grinding particularly hard mineral materials, e.g. concrete containing a high proportion of hard aggregates. Should this occur, the grinding operation must be interrupted and the diamond cup wheel allowed to cool for a short time with the tool running under no load.
- Slower progress may indicate that the diamond cup wheel has lost cutting power (segments have become polished). The segments can be resharpened by grinding an abrasive material (Hilti sharpening plate or abrasive sand-lime block).

### 7.4 Switching the tool off

1. Press the on / off switch. When released, the switch returns to the OFF position.
2. Disconnect the supply cord from the socket.
3. If an industrial vacuum cleaner is used, disconnect the hose between the tool and the vacuum cleaner.

## 8. Care and maintenance

Disconnect the supply cord plug from the socket before manipulating the DG 150 or DPC 20 (making adjustments, cleaning, etc.).

The ventilation slots in the motor housing must be unobstructed and kept clean at all times. Do not use metal objects for cleaning.

Under extreme conditions, conductive dust may collect inside the tool when grinding mineral materials. This may have a negative effect on the tool's protective insulation.

### -CAUTION-

**Keep the power tool, especially its grip surfaces, clean and free from oil and grease. Do not use cleaning agents which contain silicone.**

The outer casing of the tool is made from impactresistant plastic. Sections of the grip are made from a synthetic rubber material. Never operate the tool when the ventilation slots are blocked. Clean the ventilation slots carefully using a dry brush. Do not permit foreign objects to enter the interior of the tool. Clean the outside of the tool at regular intervals with a slightly damp cloth. Do not use a spray, steam pressure cleaning equipment or running water for cleaning. This may negatively affect the electrical safety of the tool.

### 8.1 Replacing the guard's lamellar seal

Replace the guard's lamellar seal at least each time the cup wheel is changed.

**-NOTE-** Disassembly / assembly of the seal parts can be facilitated by rotating the parts of the guard in relation to each other.

### Disassembly

1. Always switch the tool off and unplug the supply cord before making adjustments to the tool or changing parts, etc.
2. Use a screwdriver to press the three lugs of the retaining ring over the edge of the guard.
3. Remove the large lamellar seal from the retaining ring.
4. Release the small lamellar seal by pressing with a screwdriver in the two slots on the outside of the guard.

### Assembly

1. Clean the locating grooves to remove large dust particles.
2. Press the small lamellar seal into the guide in the guard until it engages.
3. Place the large lamellar seal in the groove in the retaining ring.
4. Press the retaining ring with the lamellar seal over the edge of the guard until it engages.

### 8.2 Repairs

The tool has been manufactured and tested with great care. Nevertheless, in the event of a fault developing, the tool should be returned to a Hilti service centre for repair. The tool may be repaired by trained electrical specialists only.

## 9. Troubleshooting

### 9.1 DG 150 indicator lamp (LED)

Overheating of the tool is indicated by the lamp blinking red. The lamp continues to blink for the duration of the fault, irrespective of the switch position.

In the event of the lamp blinking red, switch the tool off and allow it to cool until the red lamp no longer blinks.

### 9.2 DPC 20 indicator lamp (LED)

Indicator status:

#### a) Green lamp lights continuously

This indicates that the DPC 20 is ready for operation.

The DPC 20 is connected to the mains supply and indicates no malfunctions. This is the normal status.

#### b) Green blinking

This may occur with 100 V to 120 V versions when under load. This indicates that the mains voltage is too low. The DG 150 reacts by achieving significantly lower performance.

#### c) Red blinking

This indicates that the DPC 20 is reacting to irregularities in the electric supply (e.g. current or voltage too high, too low) or to a temperature irregularity. The indicator changes to green when the problem has been rectified. If the indicator continues to blink red, unplug the supply cord from the mains supply, wait a few seconds and then reconnect it. The output fuses should be checked if the indicator does not then change to green.

### No indication

The DPC 20 is receiving no power from the mains supply. This could be caused by the mains supply itself, the supply cord or extension cable or a fault in the DPC 20. It is not immediately possible to determine whether the indicator itself is defective. For this reason, the DPC 20 should be checked together with the DG 150 at regular intervals, at least every six months, by a trained specialist or at a Hilti service centre.

## 10. Disposal



Return waste material for recycling

Most of the materials from which Hilti electric tools are manufactured can be recycled. The materials must be correctly separated before they can be recycled. In many countries, Hilti has already made arrangements for taking back your old electric tools for recycling. Please ask your Hilti customer service department or Hilti representative for further information.



Only for EU countries

Disposal of electric tools together with household waste is not permissible!

In observance of European Directive on waste electrical and electronic equipment and its implementation in accordance with national law, electric tools that have reached the end of their life must be collected separately and returned to an environmentally compatible recycling facility.

## 11. Manufacturer's warranty – tools

Hilti warrants that the tool supplied is free of defects in material and workmanship. This warranty is valid so long as the tool is operated and handled correctly, cleaned and serviced properly and in accordance with the Hilti Operating Instructions, and the technical system is maintained. This means that only original Hilti consumables, components and spare parts may be used in the tool.

This warranty provides the free-of-charge repair or replacement of defective parts only over the entire lifespan of the tool. Parts requiring repair or replacement as a result of normal wear and tear are not covered by this warranty.

**Additional claims are excluded, unless stringent national rules prohibit such exclusion. In particular, Hilti is not obligated for direct, indirect, incidental or consequential damages, losses or expenses in connection with, or by reason of, the use of, or inability to use the tool for any purpose. Implied warranties of merchantability or fitness for a particular purpose are specifically excluded.**

For repair or replacement, send tool or related parts immediately upon discovery of the defect to the address of the local Hilti marketing organization provided.

This constitutes Hilti's entire obligation with regard to warranty and supersedes all prior or contemporaneous comments and oral or written agreements concerning warranties.

## 12. EC declaration of conformity (original)

Designation:	Diamond grinde
Type designation:	DG 150 / DPC 20
Year of design:	2001

We declare, on our sole responsibility, that this product complies with the following standards or standardisation documents: 2004/108/EG, 2006/42/EG, EN 60745-1, EN 60745-2-3, EN ISO 12100, 2011/65/EU.

**Hilti Corporation, Feldkircherstrasse 100,  
FL-9494 Schaan**

**Paolo Luccini**  
Head of BA Quality & Process Management  
BA Electric Tools & Accessories  
01/2012

**Johannes W. Huber**  
Senior Vice President  
Business Unit Diamond  
01/2012

**Technical documentation filed at:**  
Hilti Entwicklungsgesellschaft mbH  
Zulassung Elektrowerkzeuge  
Hiltistrasse 6  
86916 Kaufering  
Deutschland

\*Always follow manufacturer instructions\*

# HILTI

Hilti Corporation

LI-9494 Schaan

Tel.: +423 / 234 21 11

Fax: +423 / 234 29 65

[www.hilti.com](http://www.hilti.com)

Hilti = registered trademark of Hilti Corp., Schaan

W 2608 | 0113 | 30-Pos. 1 | 1

Printed in Liechtenstein © 2013

Right of technical and programme changes reserved S. E. & O.

371747 / A2

